



Lambda 23 VF

PANEL MOUNT, DESKTOP, REARMOUNT



Contents

1	Box contents.....	3
2	Installation.....	4
2.1	Mounting the monitor.....	4
2.1.1	Panel mount.....	4
2.1.2	VESA mount	5
2.1.3	Rearmount	5
2.2	Connecting the monitor to power and video source	6
2.3	Front controls	6
2.4	Setup for Operation (OSD-menu).....	6
2.5	OSD menu.....	8
2.6	Engineering OSD.....	10
2.7	Projected capacitive touch screen	10
3	Maintenance	11
4	Trouble shooting	12
4.1	Power	12
4.2	Image.....	12
4.3	Touch screen	12
5	Specifications	13
5.1	Video	13
5.1.1	Compatibility and video standards.....	13
5.1.2	Applicable Graphic Mode	13
5.2	Dimensions	14

1 Box contents

Please check the box contents right after receiving the equipment. The contents depend on the options ordered.

Image	Description	Remark
	Monitor	
	External power adapter (230VAC<>12VDC)	N.a. with 9~36VDC input option
	Mains cord (Euro style)	Only with external power adapter
	VGA cable (15p HD-Sub)	M/M
	DVI Cable	Optional
	RS-232 cable	Optional touch M/F
	USB cable	Optional touch A/B
	Touch driver software	Optional touch
	Mounting brackets with M5x50 screws and M5 nuts	Panel mount model only
	Mounting brackets with M4 screw	Rear mount model only
na	Optional cables	External (central) dimming), AUX

2 Installation

The Lambda 21 VF T consists of 3 models: Panel mount, VesaMount and Rear Mount. The first part of this chapter describes the universal installation of all models. Please refer to the corresponding paragraphs below for more detailed mounting description per model.

Before installation check the power source to be compatible with the power input of your monitor.

2.1 Mounting the monitor

When installing the monitor first make sure to determine the right place. There should be sufficient airflow at the back of the monitor when using the panel mount version. For any model always make sure that there is no direct sunlight on the monitor. This might heat-up the unit too much.



Determine location in compliance with the minimum radar distance mentioned on the back side of the monitor

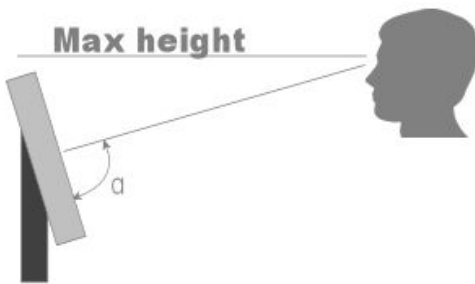

Viewing angle is an theoretical value measured with standard colors and contrast. In real life the monitor should be installed with angle: $120 < \alpha < 90$. This means that viewing from bottom side should be avoided. For viewing convenience install the monitor below eye-level (max height).

2.1.1 Panel mount

The monitor is supplied with mounting brackets for all mounting positions. All brackets need to be installed as shown in figure below to ensure safe and rigid mounting.

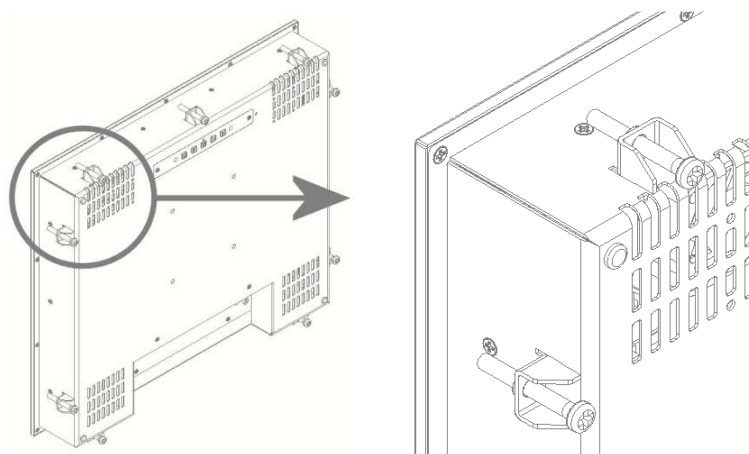

Please follow these steps for successful installation of the panel mount monitor

- Locate the right position for the monitor and take following in account:
 - Leave space around the monitor to ensure sufficient airflow for cooling to meet the temperature specifications mentioned in this manual
 - Mount the monitor in an angled position ($\geq 35^\circ$ from horizontal) to ensure airflow through the monitor
 - Make sure that there is enough airflow (cooling) in the desk. Install a cooling fan if necessary.

- Make a cutout in the desk using the corresponding dimensional drawing
- Gently slide the monitor in the cutout. Do not mechanically force any part of the monitor during installation.
- Install all mounting brackets at the back side using a PH2 screw driver. To avoid damaging the housing, do not force the screws.



To avoid the M5 screws to come loose, use M5 nuts to lock the screw to the bracket.
The VESA-mount option is not part of certification.

2.1.2 VESA mount

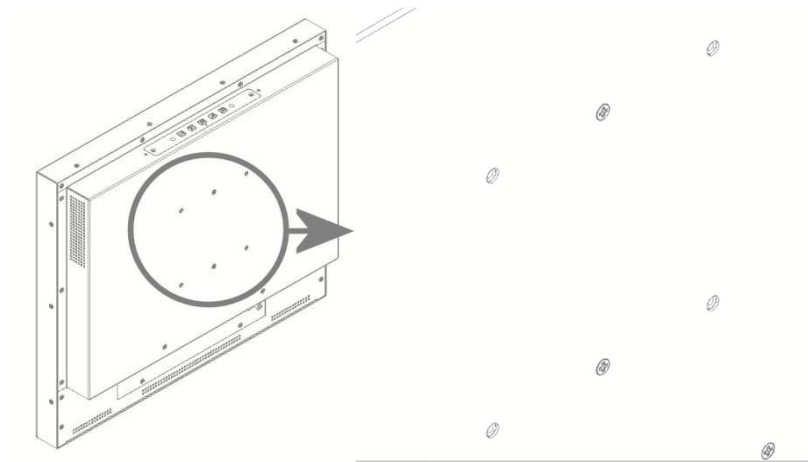

The desktop models can be mounted on any mounting bracket or pedestal corresponding with the right VESA mounting interface standard. Please refer to the dimensional drawings in this manual. Use M4 screws, max insert in the monitor is 8mm.

2.1.3 Rearmount

The rearmount monitor is supplied with sufficient brackets (incl screws) for mounting. The application dependent screws for mount to the desk or frame are not included. The maximum diameter of the screw is 4mm. Please refer to the dimensional drawings for details.

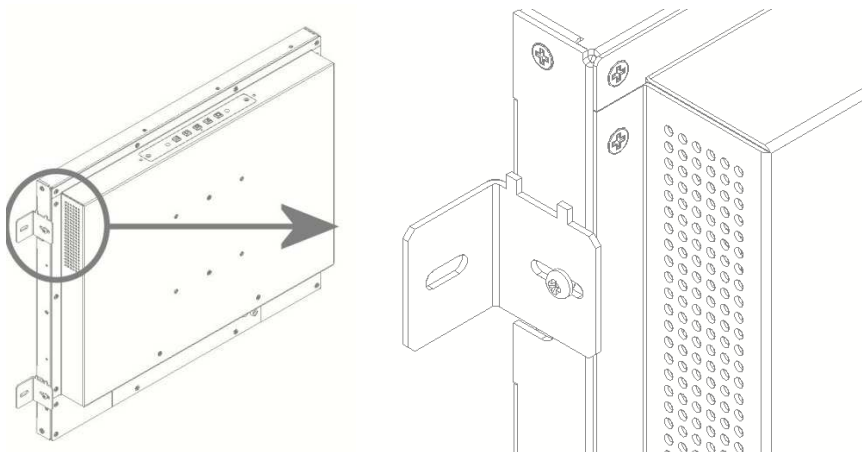

2.2 Connecting the monitor to power and video source

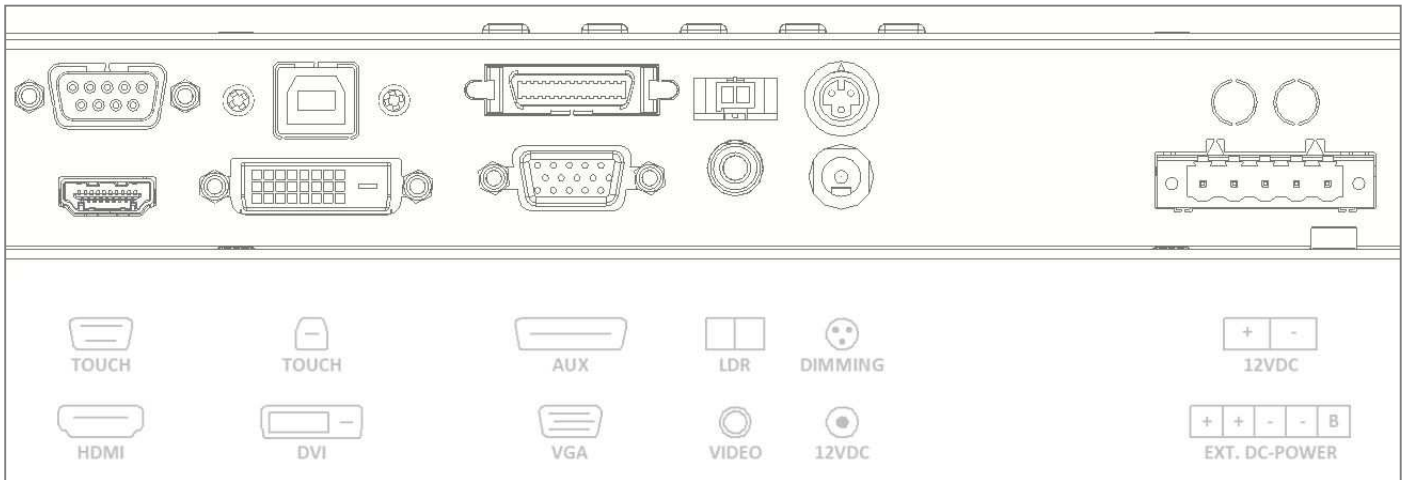

The picture above shows all connection on the I/O Bracket. For display-units with diagonal upto 12.1" the external DC-power connector counts only 2 pins, + and – :

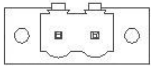

Make sure all connects are firmly fixed to the unit before powering up. For details regarding pin layouts, please refer to the chapter "Pinning".





Connect the unit to ground using the M4 screw in the I/O section marked with the grounding symbol:



2.3 Front controls

Depending on the model you have chosen, the following controls can be found at the front side of the unit:

OSD MENU Description	OSD MENU Description
Dim knob 	Dimming knob 1. Potentiometer for backlight brightness: rotate CW to increase and CCW to decrease 2. Multifunction knob: <ul style="list-style-type: none"> ○ rotate CW to increase and CCW to decrease ○ Push for standby-modus (power ON/OFF)
Capacitive switch for 'Source select' 	Touching the glass at the symbol will select the next video-input. In the OSD menu you can switch unused sources to OFF to avoid scrolling through unused sources. The status-LED next to the source select symbol shows: <ul style="list-style-type: none"> ● Green: source is available ● Red: no valid source at selected input The status-LED is dimmed simultaneously with the backlight.





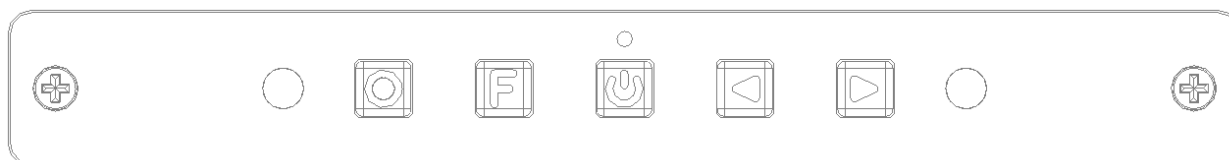

2.4 Setup for Operation (OSD-menu)

The OSD (On Screen Display) provides certain functions to have clear image and others.

This monitor supports 5 buttons OSD Menu operation as a standard.

The status-LED gives information about the signal status: Green



OSD item	Function	Hotkey function
	Menu Enter, Exit	
	Function select, Enter	Source select
	Sleep mode (ON/OFF)	
	Left, Decrease	Auto adjust. This function sets the image parameters (Phase and clock)
	Right, Increase	Backlight adjustment. Use < and > to adjust
	Status LED: Red: No signal Green: Correct input signal on selected source	

The control functions defined on OSD operation are as below.

OSD MENU Description	OSD MENU Description
Picture Mode	Picture preset mode. (Standard, Dynamic, Soft, Personal)
Contrast	Adjust the contrast of the screen.
Brightness	Adjust the brightness of the screen.
Backlight	Adjust the backlight of the screen.
Sharpness	Adjust the sharpness of the screen's image.
Tint	Adjust the tint of the screen's image.
Color	Adjust the color of the screen's image.
Color Mode	Adjust color temperature of the screen's image.
H-Pos	Adjust the horizontal position of the screen's image
V-Pos	Adjust the vertical position of the screen's image
Clock	Adjust the horizontal size of the screen's image
Phase	Adjust the focus of the screen's image
Auto	Automatically adjust the Horizontal position, Vertical position, Window's background or characters should be displayed on your full screen prior to precede this function.
3D NR	Select NR mode. (Standard, Strong, Auto, Off, Weak)
Menu Language	Select the OSD language.(English,Française,Deutsch,Italiano,Español,Nederlands)
Transparency	Adjust the OSD transparency level. (0 ~ 100%)
OSD Time Out	Define OSD time out. (5Sec ~ 60Sec)
Restore Default	Initializing that memory by factory presetting except OSD language.
Sleep Timer	Adjust the sleep timer. (0 ~ 240Min)
Zoom Mode	Select the zoom mode. (Normal, Wide, Zoom)
Image Flip	Image is reversed by vertical. (On, Off)
Image Mirror	Image is reversed by horizontal. (On, Off)
Auto Source	Detect the valid input source automatically. (On, Off)
XGA Mode	Select the resolution of RGB input (1024x768, 1280x768,,1360x768, 1366x768)
HDMI Mode	Select the HDMI image setting. (PC, Video, No Overscan)
Source	Select video input source using OSD or direct key in Remocon.

2.5 OSD menu

Symbol	Main menu	Sub Menu	
	Menu Language	English / Française / Deutsch / Italiano / Español / Nederlands	
	Transparency	0 ~ 100 %	
	OSD Time Out	5, 15, 30, 45, 60, OFF (SEC)	
	Source Setting	CVBS / HDMI / DVI / RGB : " ON " or " OFF " respectively	
	Restore Default	YES / NO	
	<u>Signal source RGB/DVI:</u>		
	Picture Mode	Standard / Dynamic / Soft / Personal	
	Contrast	0 ~ 100	
	Brightness	0 ~ 100	
	Backlight	0 ~ 100	
	Sharpness	0 ~ 100	
	Color Mode	Normal / Warm / Cool / User (R/G/B)	
	Auto Color		
	Advanced	H-Pos, V-Pos, Clock, Phase, Auto	
	<u>Signal source CVBS/HDMI:</u>		
	Picture Mode	Standard / Dynamic / Soft / Personal	
	Contrast	0 ~ 100	
	Brightness	0 ~ 100	
	Backlight	0 ~ 100	
	Sharpness	0 ~ 100	
Tint	-50 ~ +50		
Color	0 ~ 100		
Color Mode	Normal / Warm / Cool / User (R/G/B)		
3D NR	Standard / Strong / Auto / Off / Weak		

... continued on next page...

Symbol	Main menu	Sub Menu
 <p>The screenshot shows a blue-themed menu titled 'FUNCTION'. On the left, there are several circular icons: a monitor, a globe with a clock, a gear, and a globe. The menu items and their values are: Sleep Timer (Off), Zoom Mode (Wide), Image Flip (Off), Image Mirror (Off), Auto Source (Off), and XGA Mode (1024x768).</p>	Sleep Timer	OFF ~ 240 MIN
	Zoom Mode	Normal / Wide / Zoom (for CVBS & HDMI)
		Normal / Wide or RGB & DVI)
	Image Flip	ON / OFF
	Image Mirror	ON / OFF
	Auto Source	ON / OFF
	XGA Mode	1024x768 / 1280x768 / 1360x768 / 1366x768
	HDMI Mode	PC / Video / No Overscan

2.6 Engineering OSD

Optional Lambda monitors can be featured with engineering OSD function controlled by the dimming knob (encoder) or 3 external buttons (+ - and power). The functionality is limited to one-way OSD control. Please refer to the flow chart below for instructions:

(Note: if the monitor is switched off and on during this operation it could be that the knob is still in the OSD-modus. In that case wait for 10 seconds before using the knob again.)

Symbol	Encoder	External Buttons
•	Switch function of encoder (press knob to activate)	Middle button
→	Increase, rotate CW	Right button
←	Decrease, rotate CCW	Left button

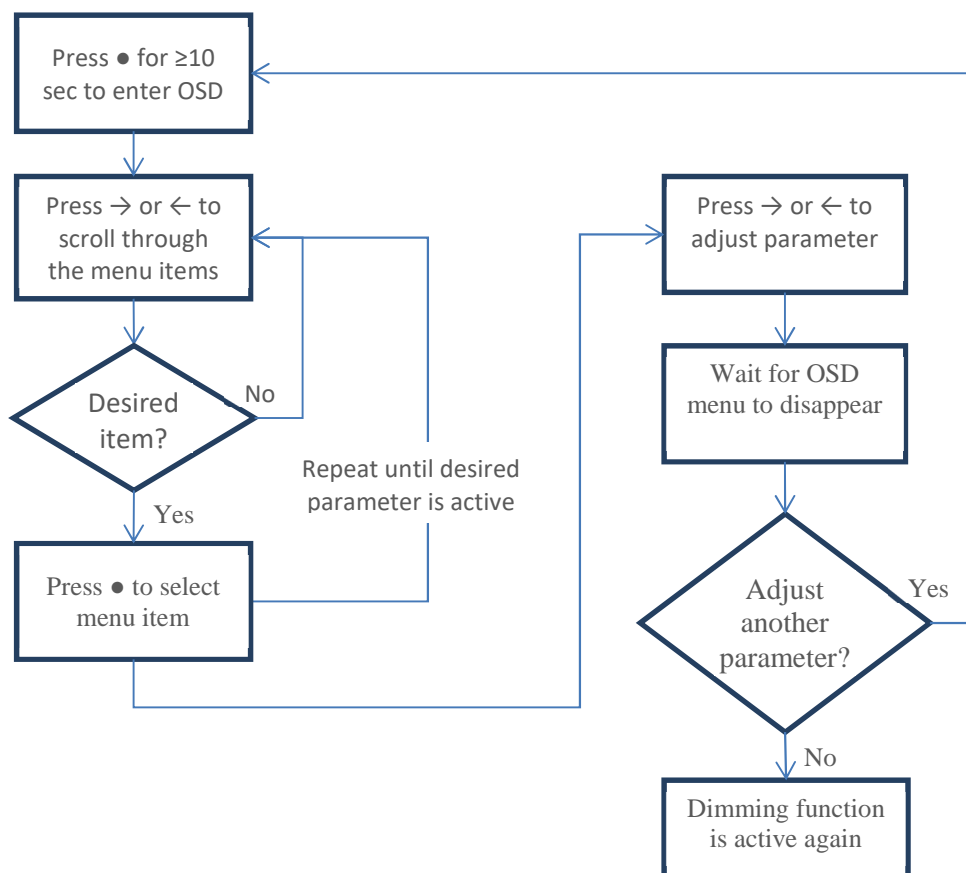

3 Maintenance

There are no user serviceable parts inside the monitor. When the monitor is used in its intended environment there is not much maintenance needed. Please follow these directions:

- Turn off the product and disconnect from the power source before cleaning or maintenance.
- To reduce the risk of electric shock, follow all safety notices and never open the touch monitor case
- Avoid dust and water to enter the monitor and never open the monitor for cleaning. This might damage the components inside.
- Clean the chassis and glass with a soft, slightly moistened cloth. Do not use any abrasive or volatile cleaners.
- Always thoroughly dry off any moisture on the monitor and glass before storing.
- Check all mounting screws if these are still sufficient secured
- Never use compressed air to clean the monitor.

4 Troubleshooting

4.1 Power

Symptom	Problem	Action
No status LED indication (with internal DC/DC converter)	<ul style="list-style-type: none"> No power to the video board 	<ul style="list-style-type: none"> Check proper pinning of power connections Check proper fitting of the wires in the screw connector Check proper fitting of the power connector in the socket Measure voltage on power connector. Should be 9~34VDC Check right dimensioning of the power cables
No status LED indication (with internal DC/DC converter)	<ul style="list-style-type: none"> No power to the video board 	<ul style="list-style-type: none"> Check proper fitting of the DC-plug in the socket Check the LED on the power adapter Check fitting of connectors on the mains power cord

4.2 Image

Symptom	Problem	Action
<ul style="list-style-type: none"> A message appears on the screen: "No signal" Status-LED lights up red and there is no image on the screen 	<ul style="list-style-type: none"> Video-source cable not connected (securely) Wrong source-mode 	<ul style="list-style-type: none"> Check proper fitting of the video cables Check the video source (PC, monitoretc.) to be powered and connected correctly Is the Video-source set to ON in the "Source Setting" OSD-menu?
<ul style="list-style-type: none"> Image colors are not shown right 	<ul style="list-style-type: none"> Missing color in the video source 	<ul style="list-style-type: none"> Check proper fitting of the VGA connector
<ul style="list-style-type: none"> Image is not positioned correctly, not centered or too small/big 	<ul style="list-style-type: none"> Pixel settings might have been changed Video source has changed Zoom mode is not set correctly 	<ul style="list-style-type: none"> Did you select the right video-mode on the source (PC)? Push the > button. This is a hot-key for auto adjustment Set the right parameter through the OSD menu-function-zoom mode

4.3 Touch screen

Symptom	Problem	Action
<ul style="list-style-type: none"> When you touch the screen no touch is detected 	<ul style="list-style-type: none"> Touch screen cable is not connected (securely) Touch drivers are not installed (resistive touch screen) 	<ul style="list-style-type: none"> Check proper fitting of the touch screen cables Install the drivers from the CD-Rom

Symptom	Problem	Action
<ul style="list-style-type: none"> A false touch is generated along the edge of the glass 	<ul style="list-style-type: none"> There is a flow of water on the surface of the glass 	<ul style="list-style-type: none"> Place the touch screen in a different edge Avoid excessive water to flow over the front surface

5 Specifications

For detailed dimensional drawings for each model

5.1 Video

5.1.1 Compatibility and video standards

- Analog RGB / DVI / HDMI / CVBS
- Full CRT multi-sync monitor compatibility
- Multi-sync capability up to WUXGA resolution @ 60Hz, compatible standard
- DOS, VGA, SVGA, XGA and SXGA / WUXGA VESA timing
- Expand DOS, VGA and SVGA to full screen display
- True color(16.7 M) data processing and display driving
- Single control operated On-Screen-Display(hereafter "OSD") user interface
- Full control of all relevant display and interface parameters via OSD
- Multi language support(5 Language and more(Optional))
- VESA DDC 1/2B compliant
- Compatible with VESA DPMS power saving modes
- Multi-standard color system at CVBS (PAL / NTSC)
- Image Flip / Mirror supportable by AD board
- Serial Control (RS232C) ready / Customized protocol setting (optional contract basis)

5.1.2 Applicable Graphic Mode

The microprocessor measures the H-sync, V-sync and V-sync/H-sync polarity for RGB inputs, and uses this timing information to control all of the display operation to get the proper image on a screen.

The monitor can detect all VESA standard and MAC Graphic modes shown on the table below and provide more clear and stable image on a screen.

Table 1 RGB Input format

Spec. Mode	Pixel Freq.		Horizontal Timing				Vertical Timing			
			Sync Polar	Freq.	Total	Active	Polar Sync	Freq.	Total	Active
	MHz			KHz	Pixel	Pixel		Hz	Line	Line
640x350@70Hz	25.144	VESA	P	31.430	800	640	N	70.000	449	350
720x400@70Hz	28.287	VESA	N	31.430	900	720	P	70.000	449	400
640x480@60Hz	25.175	MAC	N	31.469	800	640	N	59.940	525	480
640x480@60Hz	25.175	VESA	N	31.469	800	640	N	59.940	525	480
640x480@67Hz	30.240	MAC	N	35.000	864	640	N	66.667	525	480
640x480@72Hz	31.500	VESA	N	37.861	832	640	N	72.809	520	480
640x480@75Hz	31.500	VESA	N	37.500	840	640	N	75.000	500	480
832x624@75Hz	57.284	MAC	N	49.726	1152	832	N	74.551	667	624
800x600@56Hz	36.000	VESA	P	35.156	1024	800	P	56.250	625	600
800x600@60Hz	40.000	VESA	P	37.879	1056	800	P	60.317	628	600
800x600@72Hz	50.000	VESA	P	48.077	1040	800	P	72.188	666	600

800x600@75Hz	49.500	VESA	P	46.875	1056	800	P	75.000	625	600
1024x768@60Hz	65.000	VESA	N	48.363	1344	1024	N	60.005	806	768
1024x768@60Hz	64.000	MAC	N	48.780	1312	1024	N	60.001	813	768
1024x768@70Hz	75.000	VESA	N	56.476	1328	1024	N	70.070	806	768
1024x768@75Hz	80.000	MAC	N	60.241	1328	1024	N	74.927	804	768
1024x768@75Hz	78.750	VESA	P	60.023	1312	1024	P	75.030	800	768
1280x768@60Hz	79.500	VESA	P	47.780	1664	1280	P	59.870	798	768
1280x1024@60Hz	108.000	VESA	P	63.981	1688	1280	P	60.020	1066	1024
1280x1024@75Hz	135.000	VESA	P	79.976	1688	1280	P	75.025	1066	1024
1360x768@60Hz	85.000	VESA	P	47.712	1792	1360	P	60.015	795	768
1600x1200@60Hz	160.875	VESA	N	74.479	2160	1600	P	59.967	1242	1200
1680x1050@60Hz	147.000	VESA	N	65.160	2256	1680	P	59.944	1087	1050
1920x1080@60Hz	172.750	VESA	N	67.061	2576	1920	P	59.983	1118	1080
1920x1200@60Hz	193.125	VESA	N	74.508	1292	1920	P	59.990	1242	1200

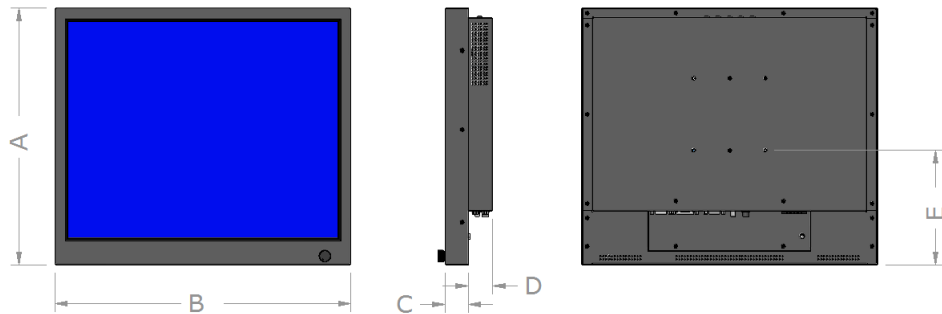

5.2 Dimensions

Model	A	B	C	D	E	VESA
N230	343.6	549.8	32	34	151.8	100mm